

# CHALLENGER

# WATERMARK BRASS BALL VALVE

# MODEL DZR

## FEATURES

- SIZE RANGE: 8MM - 50MM
- WATERMARK W581
- 16 BAR RATED
- TEMP 150° C
- THREADS: UNI ISO 7/1 - Rp
- AGA CERTIFICATE 5160

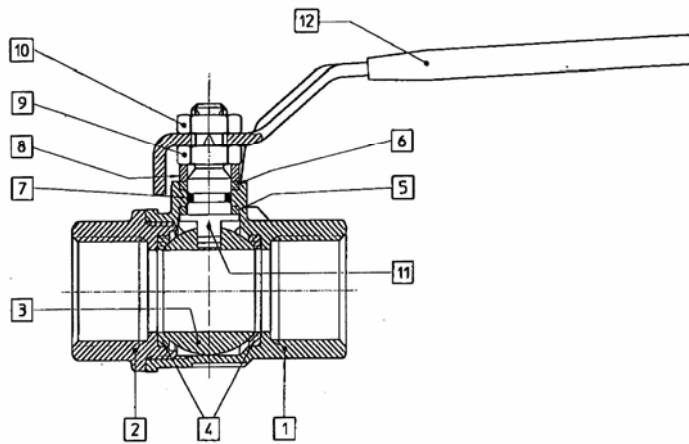
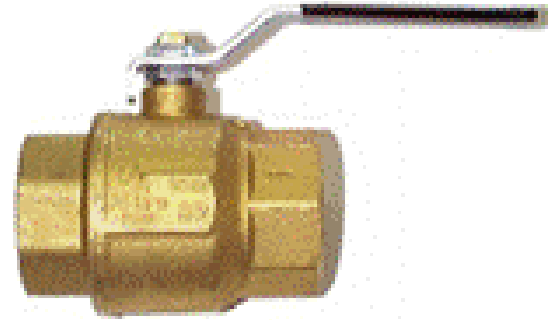

ITEM	COMPONENT	MATERIAL (ASTM)
1	BODY	CW602N UNI 12165 (DZR)
2	END CONNECTION	CW602N UNI 12165 (DZR)
3	BALL	CW602N UNI 12165 (DZR)
4	BALL SEAT	PTFE
6	ANTIFRICTION RING	PTFE
7	'O' RING	NBR 75
8	PACKING GLAND	CW617N UNI EN 12164
9	NUT	STEEL 6S
10	NUT	STEEL 6S
11	STEM	Fe P 11 UNI 5867
12	LEVER HANDLE	ZINC-PVC SLEEVE

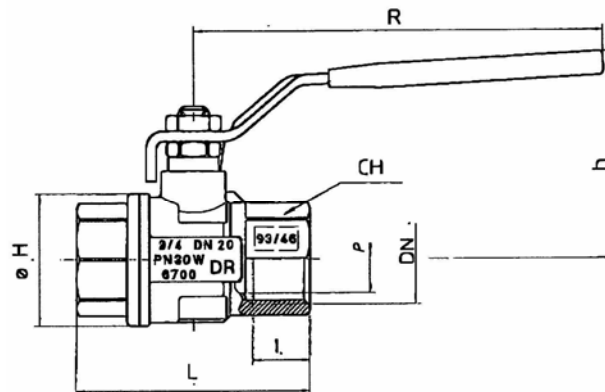

DIMENSIONS								
SIZE MM	8	10	15	20	25	32	40	50
FACE TO FACE - L	51.5	51.5	62	69	83	96	108	126
VALVE CENTRE TO TOP - h	42	42	46	58	62	75.5	82	94
HANDLE - R	95	95	95	120	120	150	150	159
VALVE - H Ø	42	42	46	58	62	75.5	82	94